

## CashPlus Midi

CashPlus is a generic portfolio of cash drawers, and has been selected from over 10,000 designs to reflect the unparalleled quality and flexibility that is customary to all Cash Bases products. Each drawer offers unique features, configurable inserts and variable dimensions, suitable for any retail environment, anywhere in the world.

### DESCRIPTION

A robust and rugged performer with a high capacity, rotatable and adjustable insert for all notes, coins and media storage. The Midi is ideal for busy retail environments where there is a high volume of cash transaction.

### FEATURES

- Robust steel construction
- Steel ball bearing runners
- Quick release tray
- Drawer status micro switch
- Bolt down facility in baseboard

### OPTIONS

- Rotatable insert
- Floppy note dividers to maximize note storage
- Fixed or removable coin cups
- Coin cups suitable for weigh counting
- Media posting slot
- Lockable lid for the insert
- Emergency key release, 3 position or no lock
- Alike or random locks
- Support bracket for under counter mounting
- Rear cable guard for cable management

### SPECIFICATION

- Width: 380mm
- Depth: 426mm
- Height: 130mm
- Drawer ejection: 374mm
- Weight: 13kg

### IDEAL FOR

- CTN's
- Lotteries
- Pharmacists

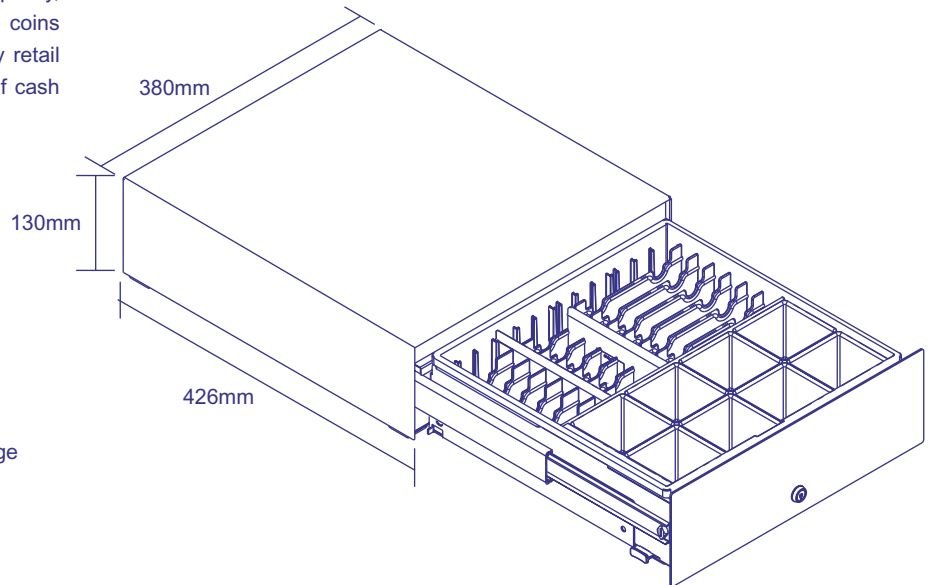

LUK/CASH-MIDI/0803

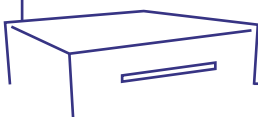

Specification may be subject to change without notification